

DISTRIBUTEURS MONOBLOC ET EMPILABLES - MONOBLOCK AND SECTIONAL VALVES

BM 150

Qn
140 l/min

Q max
180 l/min

BM 180

Qn
170 l/min

Q max
190 l/min

**DISTRIBUTEUR MONOBLOC
MONOBLOCK VALVE**

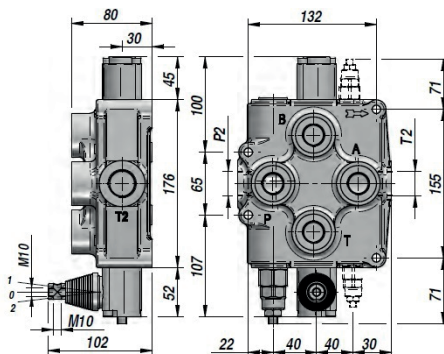
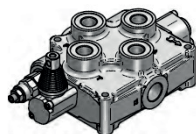

SCHEMA AVEC "VLC-AB"
DIAGRAM WITH "VLC-AB"

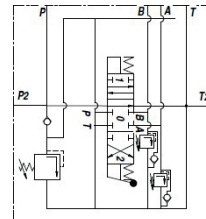

Code Code	Type Type	N° Leviers Sections No.	Orifices - Threads					PN bar	P MAX U bar	P MAX S bar	L	I	kg
			A-B BSP	P BSP	T BSP	P2 BSP	T2 BSP						
DBM6111001	BM150/1/GU/MO A1	1	3/4"	3/4"	3/4"	1"	1"	250	320	80	160	132	8,2
DBM7111001	BM180/1/GU/MO A1	2	1"	1"	1"	1"	1"	250	320	80	160	132	8,2

PN = Pression nominale - Nominal pressure

P MAX U = Pression maxi sur les orifices - Max. pressure on ports

P MAX S = Pression maxi sur le retour - Max. pressure in tank-line

Limiteur de pression - Relief Valve : X=30:90 bar (70) - U= 80:230 bar (140) (Standard) - K= 150:300 bar (200)

SUR DEMANDE : VALVES AUXILIAIRES VL = LIMITEUR DE PRESSION - VC = VALVE ANTICAVITATION - VLC = LIMITEUR DE PRESSION ET VALVE ANTICAVITATION

ON REQUEST : AUXILIARY VALVES VL = RELIEF VALVE - VC = ANTICAVITATION VALVE - VLC = RELIEF VALVE AND ANTICAVITATION VALVE

LES CODES CORRESPONDENT A : DOUBLE EFFET - 3 POSITIONS - RAPPEL RESSORT - A/B FERMEE - ORIFICES BSP - PREDISPOSITION POUR CENTRE A SUIVRE

THESE CODES REFER TO: DOUBLE ACTING TYPE - 3 POSITIONS - SPRING RETURN - A/B PORTS CLOSED - BSP THREADS - MACHINED FOR CARRY-OVER

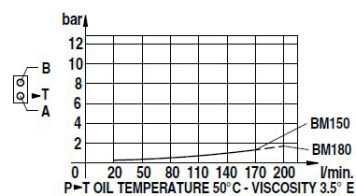
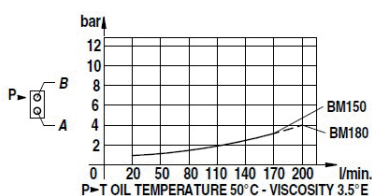
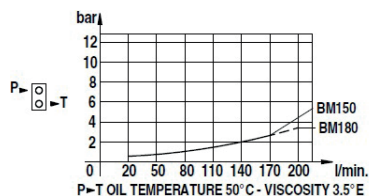

TIROIR SPOOL TYPE	
A	
B	
C	
D	

POSITIONNEUR SPOOL CONTROL	
1	
2	
3	
6	
7	
8	

SUR DEMANDE ON REQUEST	
MC	Commande manuelle + téton Manual control with cam
DO	Come de commande Cam operator
1P	Commande pneumatique Pneumatic operator
HO	Commande hydraulique Hydraulic control
MSW	Microrupteur Microswitch
CO	Centre a suivre Power beyond (carry over)
CCP	Centre fermé Closed center plug

BM180

Monosezione

Portata 170 l/min

Utilizzi 1" BSP / SAE 14

Doppia entrata e uscita

Predisposto per continuazione di pressione (Carry Over)

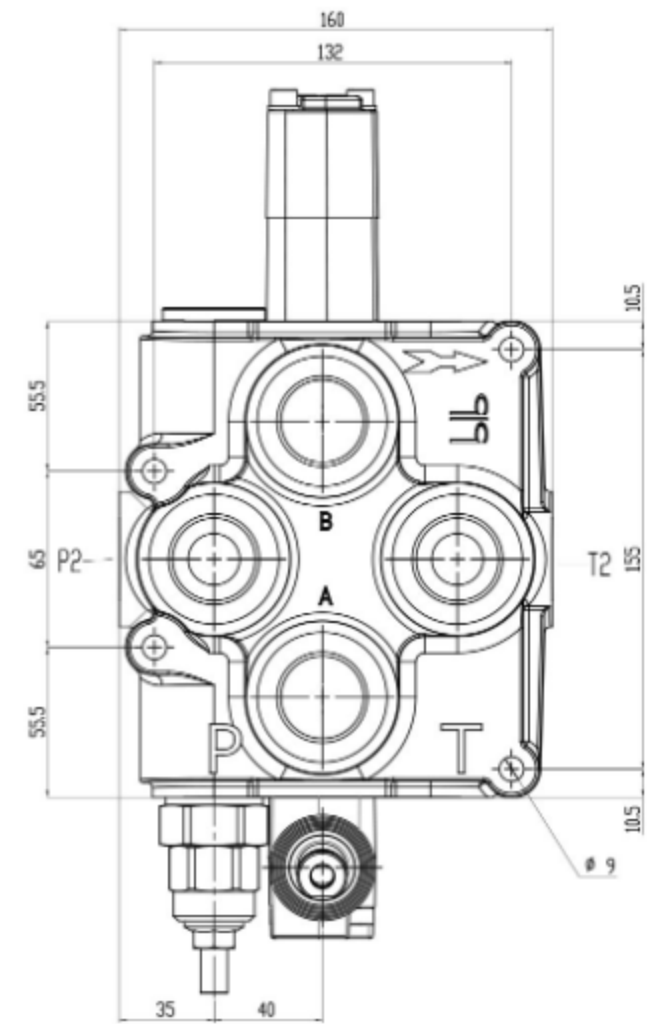
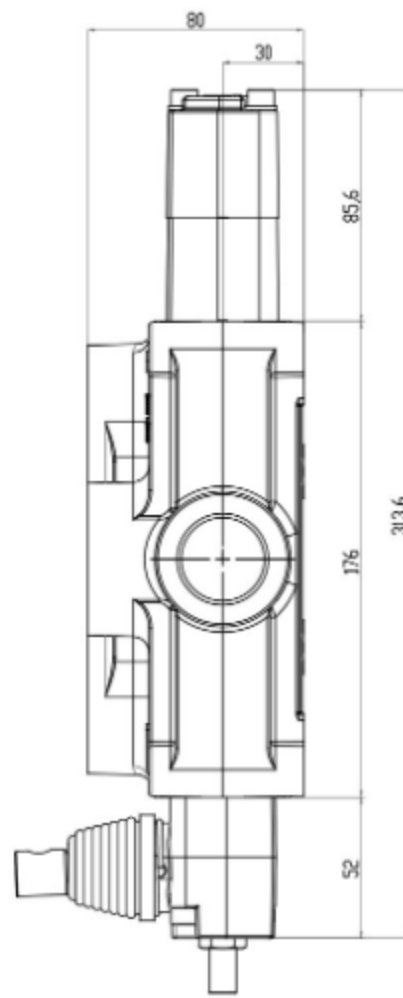

SPECIFICHE TECNICHE / TECHNICAL SPECIFICATIONS		FILETTATURE STANDARD / STANDARD THREADS						
PORTATA NOMINALE / NOMINAL FLOW	170 L/min	45 GPM						
PORTATA MAX / MAX FLOW	190 L/min	50 GPM						
PRESSIONE NOMINALE / NOMINAL PRESSURE	250 bar	3600 PSI						
PRESSIONE MAX SUGLI UTILIZZI / MAX PRESSURE ON PORTS	320 bar	4700 PSI						
CONTROPRESSIONE MAX ALLO SCARICO / MAX PRESSURE ON TANK LINE	80 bar	1100 PSI						
			A - B	P	T	P2	T2	
			G (BSP)	1"	1"	1"	1"	1"
			F (UNF - SAE 14)	1,5/16"-12	1,5/16"-12	1,5/16"-12	1,5/16"-12	1,5/16"-12

TRAFILAMENTI INTERNI / INTERNAL OIL LEAKAGE	
A - B → T	4 ÷ 8 cc/min
CONDIZIONI DI TEST / TESTING CONDITIONS	
PRESSIONE / PRESSURE	100 bar
TEMPERATURA DELL'OLIO / OIL TEMPERATURE	40 °C
VISCOSITÀ DELL'OLIO / OIL VISCOSITY	32 mm ² /s

DIMENSIONI / DIMENSIONS				
N. DI SEZIONI / N. OF SECTIONS	L		I	
	mm	inch	mm	inch
BM180	160	6,30	132	5,20

PERDITE DI CARICO / PRESSURE DROP

